

ISS	REVISED BY:	REVISION DATE	ECD #

NOTES:

MATERIAL:
 PLATE - STEEL, 36 KSI YIELD
 HELIX - STEEL, 55 KSI YIELD
 PIPE - STEEL, 50 KSI YIELD
 STINGER - STEEL, 50 KSI YIELD

WELDING REQUIREMENTS:
 ALL WELDING TO BE PERFORMED BY WELDERS CERTIFIED UNDER SECTION 5 OF AWS D1.1

FINISH:
 HOT DIP GALVANIZED PER ASTM A123
 HOT DIP GALVANIZED PER ASTM A153 (HDW)

DIMENSIONS: INCHES

HARDWARE:
 CARRIAGE BOLT, 1Ø PER ASTM A325 (4 EA)
 HEX JAM NUT, 1Ø PER ASTM A563 (4 EA)
 FLAT WASHER, 1Ø PER ANSI B27.2 (4 EA)

MECHANICAL RATING:
 ULTIMATE INSTALLATION TORQUE - 10,000 FT-LBS

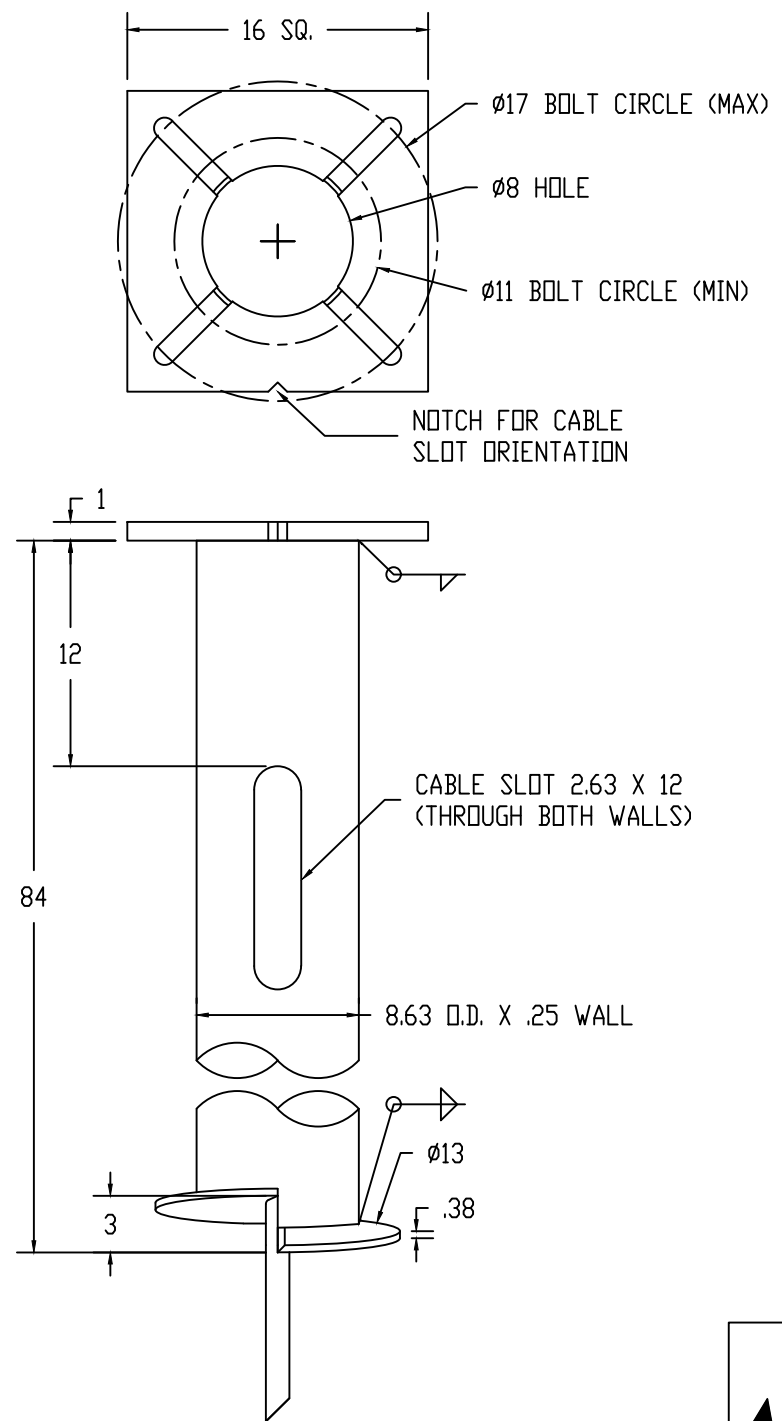

This drawing contains confidential information that is the property of MacLean Power, L.L.C. ("MacLean"). Use of MacLean's confidential information without MacLean's express written consent is strictly prohibited and may expose you to legal liability. If you believe that you received this material in error, please destroy it or return it to MacLean Power, L.L.C., Kingsley Park Five, 481 Munn Rd. Suite 300, Fort Mill, SC 29715, USA.



WWW.MACLEANPOWER.COM

CATALOG NUMBER: D08084BBB11178V		
SHEET NAME: Sheet1	1 OF 1	
DRAWING DESCRIPTION: STREET LIGHT FOUNDATION Ø8-5/8" X 84" PIPE 11"-17" VARIABLE BOLT CIRCLE		
DRAWN BY: DH	DATE: 08/07/20	APPRVD: DR