

ISS	REVISED BY:	REVISION DATE	ECO #

NOTES:

MATERIAL:
 HELIX - STEEL, 55 KSI YIELD
 RCS - SHAFT STEEL, 90 KSI YIELD

WELDING REQUIREMENTS:
 ALL WELDING TO BE PERFORMED BY WELDERS CERTIFIED UNDER SECTION 5 OF AWS D1.1

FINISH:
 HOT DIP GALVANIZED PER ASTM A123

DIMENSIONS: INCHES

REQUIREMENTS:
 METAL MUST BE MELTED AND ALL PROCESSING PERFORMED IN THE USA. MUST INCLUDE CERTIFICATE THAT THE PART MEETS FHWA 'BUY AMERICA' REQUIREMENTS.

MECHANICAL RATING:
 TORQUE - 10,400 FT-LBS
 Kt FACTOR - 10
 ULTIMATE AXIAL CAPACITY - 100.5 KIPS

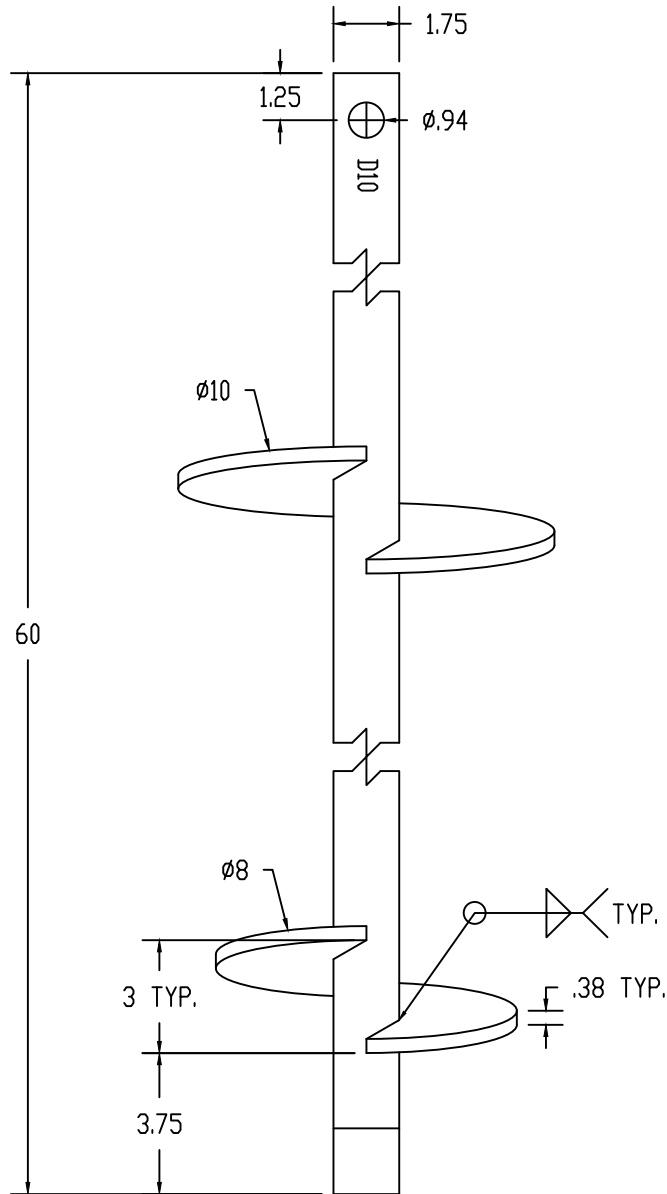

This drawing contains confidential information that is the property of MacLean Power, L.L.C. ("MacLean"). Use of MacLean's confidential information without MacLean's express written consent is strictly prohibited and may expose you to legal liability. If you believe that you received this material in error, please destroy it or return it to MacLean Power, L.L.C., Kingsley Park Five, 481 Munn Rd. Suite 300, Fort Mill, SC 29715, USA.



WWW.MACLEANPOWER.COM

CATALOG NUMBER: D17532-US		
SHEET NAME: Sheet1	1 OF 1	
DRAWING DESCRIPTION: RCS LEAD D10, MULTI-HELIX, BUY AMERICA 1-3/4" X 60"		
DRAWN BY: DH	DATE: 08/10/20	APPROVED: DR