

ISS	REVISED BY:	REVISION DATE	ECD #
-----	-------------	---------------	-------

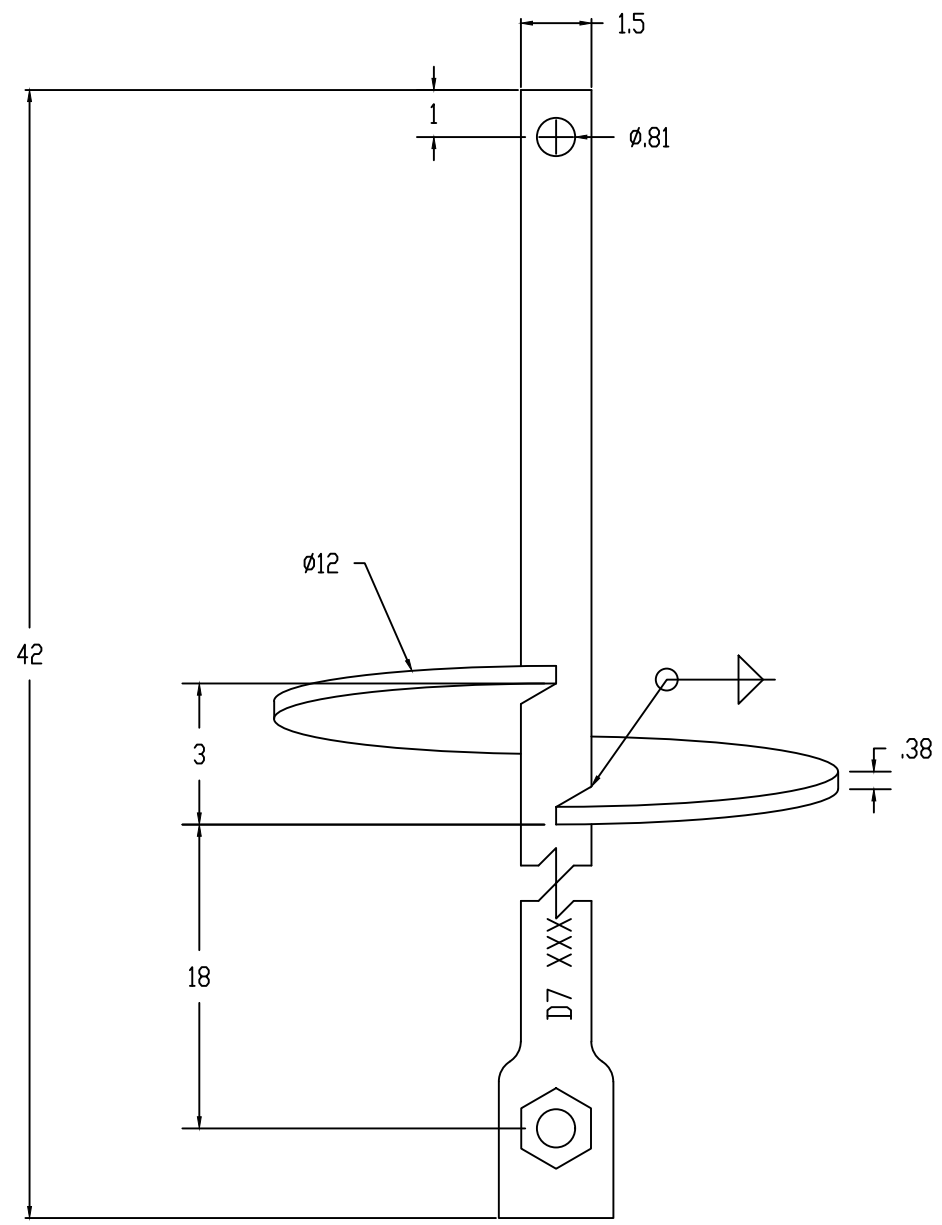

NOTES:

MATERIAL:
RCS SHAFT; STEEL, 90 KSI YIELD
HELIX; STEEL, 55 KSI YIELD

WELDING REQUIREMENTS:
ALL WELDING TO BE PERFORMED BY WELDERS CERTIFIED UNDER SECTION 5 OF AWS D1.1

FINISH:
HOT DIP GALVANIZED PER ASTM A123
HOT DIP GALVANIZED PER ASTM A153 (HDW)

DIMENSIONS: INCHES

REQUIREMENTS:
METAL MUST BE MELTED AND ALL PROCESSING PERFORMED IN THE USA. MUST INCLUDE CERTIFICATE THAT THE PART MEETS FHWA 'BUY AMERICA' REQUIREMENTS.

HARDWARE:
HEX HEAD BOLT, 3/4" PER ASTM A325 (1 EA)
HEX JAM NUT, 3/4" PER ASTM A563 (1 EA)

MECHANICAL RATING:
TORQUE - 7,000 FT-LBS
Kt FACTOR - 10
ULTIMATE AXIAL CAPACITY - 70 KIPS

CATALOG NUMBER: D6616UC7-US		
SHEET NAME: Sheet1	1 OF 1	
DRAWING DESCRIPTION: EXTENSION BAR D7, W/HELIX, BUY AMERICA 1-1/2" X 42"		
DRAWN BY: DH	DATE: 08/10/20	APPROVED: DR



WWW.MACLEANPOWER.COM

This drawing contains confidential information that is the property of MacLean Power, L.L.C. ("MacLean"). Use of MacLean's confidential information without MacLean's express written consent is strictly prohibited and may expose you to legal liability. If you believe that you received this material in error, please destroy it or return it to MacLean Power, L.L.C., Kingsley Park Five, 481 Munn Rd. Suite 300, Fort Mill, SC 29715, USA.