

ISS	REVISED BY:	REVISION DATE	ECD #
1	DH	03/26/21	A10180

NOTES:

\*ICC-ES EVALUATION REPORT ESR-3032 ACCREDITED PRODUCT\*

MATERIAL:  
 HELIX - STEEL, 55 KSI YIELD  
 RCS - SHAFT STEEL, 70 KSI YIELD

WELDING REQUIREMENTS:  
 ALL WELDING TO BE PERFORMED BY WELDERS CERTIFIED  
 UNDER SECTION 5 OF AWS D1.1

FINISH:  
 HOT DIP GALVANIZED PER ASTM A123

DIMENSIONS: INCHES

MECHANICAL RATING:  
 TORQUE - 5,500 FT-LBS  
 Kt FACTOR - 10  
 ULTIMATE AXIAL CAPACITY - 68 KIPS

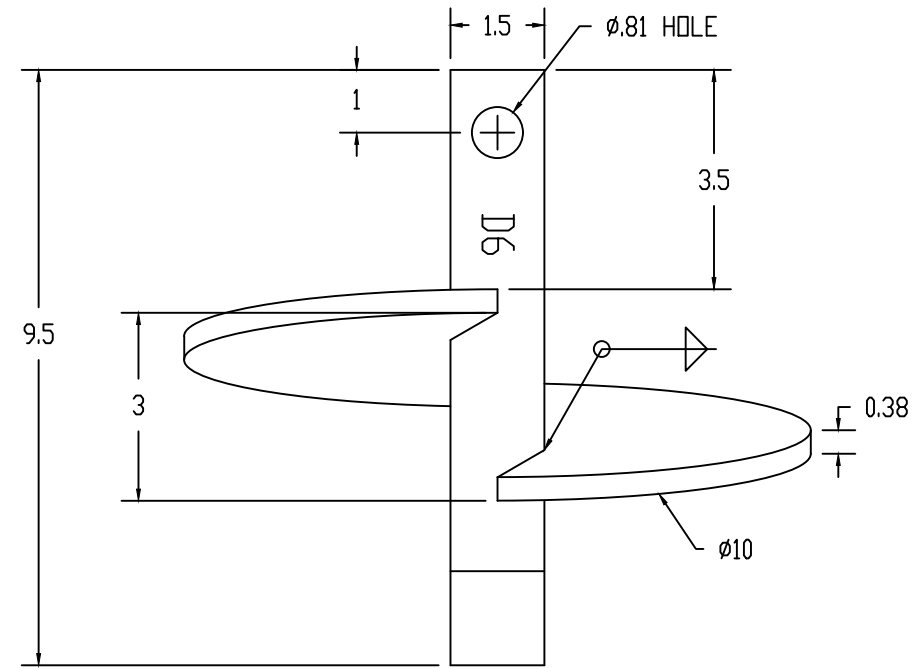

This drawing contains confidential information that is the property of MacLean Power, L.L.C. ("MacLean"). Use of MacLean's confidential information without MacLean's express written consent is strictly prohibited and may expose you to legal liability. If you believe that you received this material in error, please destroy it or return it to MacLean Power, L.L.C., Kingsley Park Five, 481 Munn Rd. Suite 300, Fort Mill, SC 29715, USA.



WWW.MACLEANPOWER.COM

CATALOG NUMBER: D69.5S10		
SHEET NAME: Sheet1	1 OF 1	
DRAWING DESCRIPTION: RCS LEAD D6, W/ HELIX 1-1/2" X 9-1/2"		
DRAWN BY: DH	DATE: 03/26/21	APPROVED: BAB