

THE LEADING EDGE OF HELICAL FOUNDATIONS



TYPICAL APPLICATIONS

- **COMMERCIAL**
- **INDUSTRIAL**
- **DATA CENTERS**
- **MIXED USE BUILDINGS**
- **MID/HIGH RISE**

Installs with readily available equipment
Substantial time and cost savings
No spoils or drill tailings

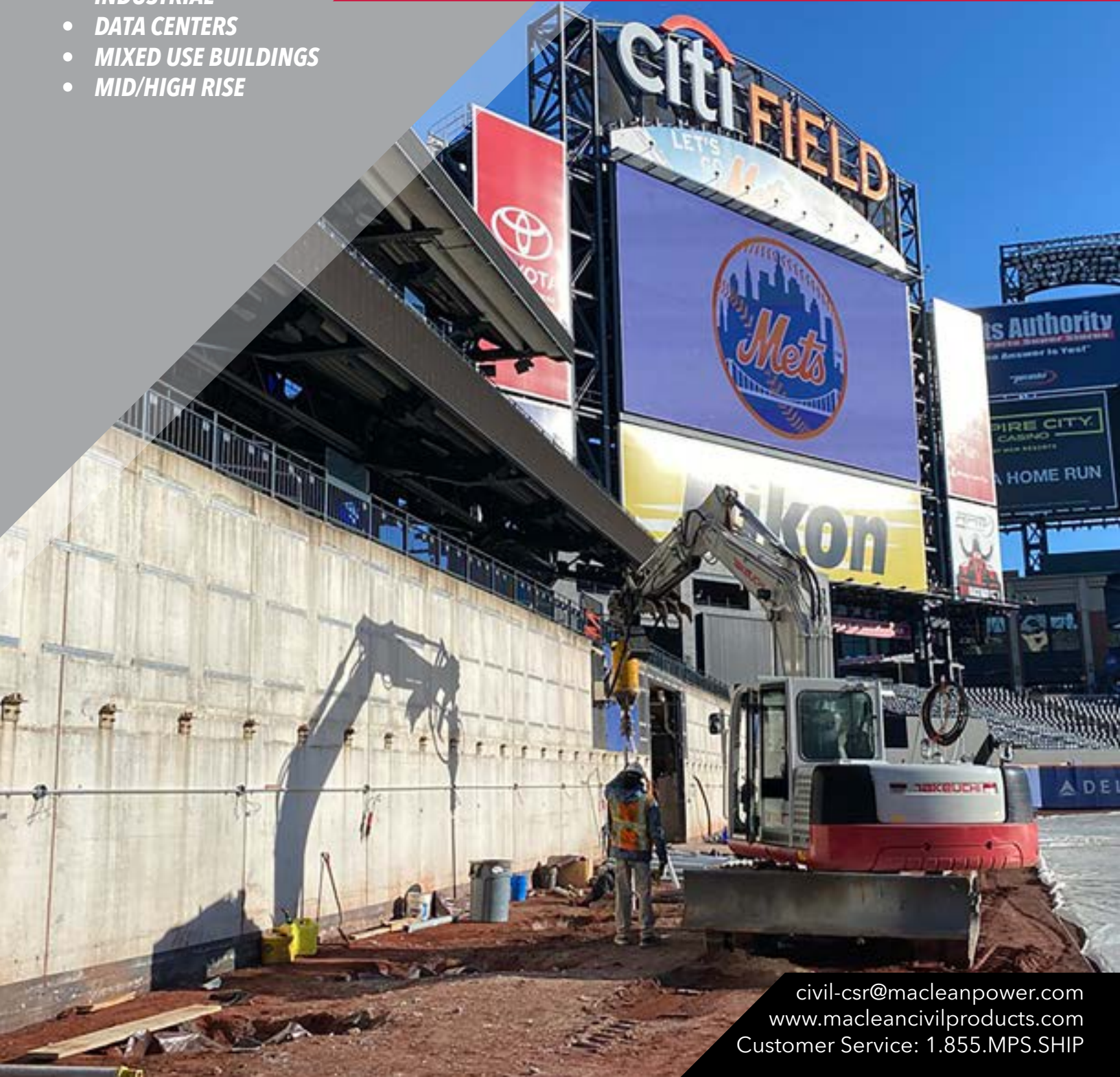

civil-csr@macleanpower.com
www.macleancivilproducts.com
Customer Service: 1.855.MPS.SHIP

MacLean Civil Products

With so many deep foundation and anchoring options available on the market today it can be a daunting task attempting to choose the right one. It's easy to freeze up weighing the pros and cons of each when deciding which route is the best to go down. If your goal is to deliver a solid, stable, and safe foundation then look no further than helical piles.

Why our helical piles are the best choice.

Helical piles offer several advantages over other deep foundation technologies. They do not create any spoils, can be easily removed and relocated/reused, and can be installed in any weather/groundwater condition to name just a few.

What sets MacLean's helical piles apart is the leading edge on our helix and our Strength Squared™ pipe coupling system.

The Leading Edge.

Straight leading edges on helix can get caught and snagged on tree roots, debris in fill soils, and coarse gravel/cobbles. This can lead to artificially higher torque readings and impede the pile from advancing to proper load bearing soil.

The curved edge on helix minimizes these issues and allows for smoother installations without installation torque spikes wearing on the pile and your equipment.

Superior Connections.

Couplings are often an overlooked aspect of helical piles. Pipe sleeve couplings inject several pain points into the equation. They are time consuming and labor intensive to work with. They focus all of the installation torque through the hardware leading to bolt hole egging and a struggle to get the hardware installed.

Our Strength Squared™ coupler system eliminates all of these pain points. The square-on-square engagement readily couples together and presents perfectly aligned bolt holes instantly offering significant time savings. The geometry of our coupler efficiently transfers the torque away from the bolt holes leading to zero deformation.

Quality You Can Depend On.

Why lose sleep at night dealing with foreign made products with unverifiable quality? At MPS we fabricate our civil products domestically in our ISO 9001:2015 certified facility. Our products are also submitted to 3rd party testing to verify our product ratings through ICC Evaluation Service®.



MCP's proprietary curved helix reduces torque spikes for smoother installations.



Improved pile performance with our Strength Squared™ coupling system



MacLean Civil Products' manufacturing facility

Specialty Applications

Walkways: Shangri-la Botanical Gardens

– Orange, Texas

Over 850 helical piles were used as the foundation system to support a new 2,400ft long wooden boardwalk through wetlands, swamps, and ponds. A series of 1-1/2" RCS piles were installed vertically and battered to depths of 15-25 feet to resist working loads of 15 kips axial and 10 kips lateral.

In addition to the boardwalk, helical piles were also used in this remote area to support three classrooms, a bird blind, and a nature discovery building.

Marine application: Inlet Watch Marina and Yacht Club

– Wilmington, North Carolina

A deteriorating bulkhead was replaced with new fiberglass sheet piles anchored with two rows of 1-1/2" RCS helicals. 208 total helical anchors were used to support the new 700ft long bulkhead. Anchors were installed 15 to 20ft deep to resist working tension loads up to 21 kips.

Many challenges were faced on this project due to the presence of buried wooden debris, loose wet sand, and changing water levels. By choosing helical anchors, the contractor was able to finish the project ahead of schedule.

Lighting application: for roadway streetlights, signage poles and commercial lampposts

– Suitable for all locations and climates.

MPS offers a full line of helical streetlight foundations. These helical foundations are rotated into the soil, replacing precast and cast-in-place concrete foundations. Once installed, they are ready for immediate pole mounting. Cutting down your installation time from hours or days to mere minutes and without any cuttings or spoils to haul away.

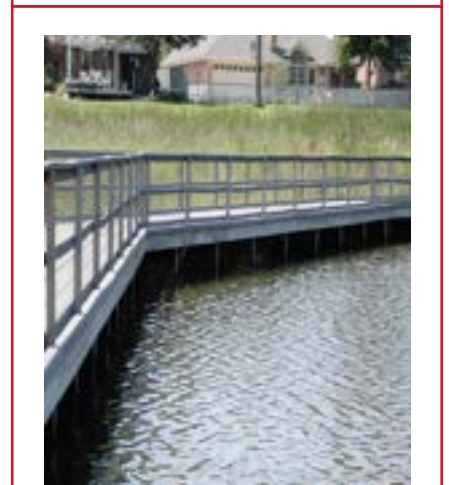

Marinas, Walkways and Lighting

The product of choice from coast to coast.

Helical piles are an environmentally friendly and long lasting solution. All that's needed to install them is light duty rubber tracked or portable equipment. They can be installed in any weather condition including through frozen ground and even asphalt to tackle projects of any shape and size.

- Ideal substitute for antiquated dead men anchors
- Used to Replace deteriorating wooden dock piles
- Minimal environmental impact - no vibrations or spoils
- Galvanized finish for corrosion protection and longevity

No better way to install walkways.

Conventional helical piles can be used to support light bridges, golf cart paths, and walkways through swamps and marshes. A series of braced brackets with intermittently placed tension anchors consisting of helical piles are usually capped with a wood deck and railing system. The installation of a helical walkway system limits the disturbance in sensitive areas like wetlands, botanical gardens or beachfronts. No access road is required, just your own lightweight equipment outfitted with a hydraulic driver.

Shedding light on a more economical foundation system.

Our single piece Streetlight Foundation system can be used when installing roadway area lighting and signage poles. These foundations offer significant material and labor savings over traditional cast-in-place or precast concrete foundations.

- No spoils to haul away
- Ready for immediate loading
- Installed in as little as 10 minutes
- Requires less equipment and smaller crews

Typical Walkway Helical Anchors

MacLean Civil helical piles for walkway applications are available in single and multiple helix configurations. Typical shaft sizes for this application range from 1.5" to 1.75" solid square and 2.875" to 3.5" pipe.

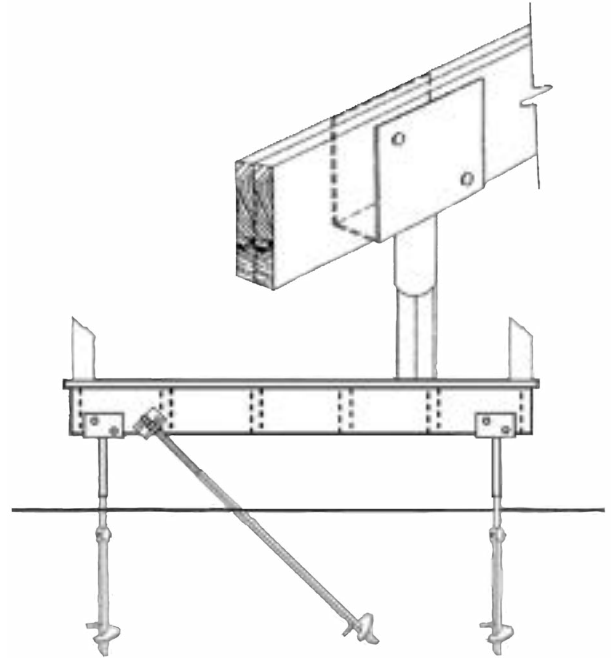

Standard lighting foundation material specifications

- Available in 6", 8" and 10" diameter sizes
- Lengths from 5 -10 feet
- Includes wiring slot opening for cables
- Top plate configurations to meet pole plate base dimensions
- Hot dip galvanized to ASTM A123/A153
- Typically installed for lighting poles to 50" height

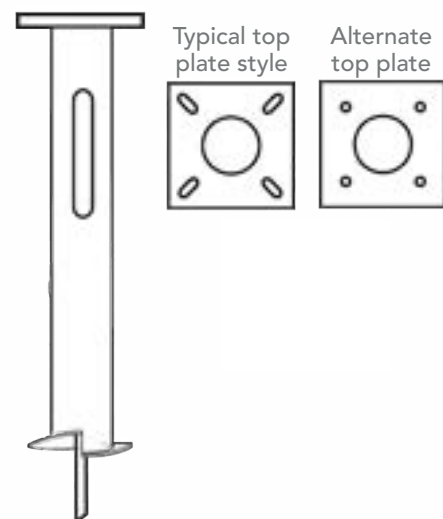

Build on our solid foundation.

Lot line to lot line: residential structure

– Brooklyn, New York

This new six-story residential structure was planned next to buildings with foundations over 100 years old. Though initial soil data pointed toward a spread footing, the site conditions discovered during excavation called for a revised deep foundation system.

Helical piles were chosen due to their near zero soil disturbance and vibrations during installation so as not to disturb the adjacent buildings. This quick pivot kept the project on schedule. A total of 54 piles were installed to an ultimate capacity of 80 kips using D10 1-3/4" RCS piles to an average depth of 30 feet.

Pure helical pile foundation system: CVS Pharmacy – Dallas, Texas

Helical piles were chosen to support two buildings on a site with highly expansive clays using 1-1/2" and 1-3/4" RCS piles with 6" x 6" x 1/2" steel pile caps. The pile caps were cast into the concrete floor slab, transferring the building load directly on the helical piles to effectively neutralize the expansive clay soils.

A single crew was able to install all 285 piles to depths of 15 to 25 ft on this project in 7 working days. This allowed the concrete contractor to begin their work ahead of schedule. A load test was performed to verify that the helicals would perform as expected in the poor soil conditions present on this site.

Unique foundation structure: Metro-North's Riverdale Station Art – Riverdale, New York

When Metro-North's Riverdale railroad station in the Bronx was refurbished, the project included the installation of a large, perforated steel sculpture on the outdoor grounds. The site chosen for the artwork posed several challenges. The site was littered with numerous underground utilities, had very limited access due to a new fence and landscaping that couldn't be disturbed, and large resultant wind loads from the size of the sculpture itself.

Helical piles were chosen on this project due to the small equipment required to install them and the near zero vibrations or other soil disturbances during installation.

22 battered piles were installed at angles to resist the large moment loading. The batter angles and pile depths were carefully planned to not disturb the existing underground utilities.



Easy installation. Easy on your budget.

Why use MacLean Civil's helical piles for your new construction projects? The reason is simple—and so is the installation. There's no heavy excavating equipment needed, minimal noise compared to a pile driver and no vibration or disturbance to surrounding structures. Our helical piles install quickly—in fact, a 20-foot long pile can be installed in just minutes. Since there's no concrete required, there's no cure time. And construction of footings can begin immediately after piles are installed. So you save time, plus money and manpower.

Stabilize structures on all soil types.

Helical piles are installed to a preplanned depth and torque to ensure they become embedded in dense, load bearing soil. The piles are tied into the foundation rebar grid before the footings are poured. Once the final foundations are in place, the structural load is transferred to the helical piles, creating rock solid stability. And MacLean Civil's piles can be used in all soil types ranging from soft sand to compressible clay to areas with high water tables.

The basics of a helical pile.

Helical piles are available in two shaft types. Solid square shafts are typically used in tension and light compression load applications such as tieback anchors or residential foundation underpinning. Pipe piles are able to resist larger lateral, buckling, and compressive loads. Helix diameters—from 6 to 16 inches—are based on load requirements and are designed to "track" for minimal disruption of soil during installation. It is possible to improve square shaft helicals' ability to resist lateral and buckling loads by encasing the extensions in a grout column. This can be readily formed by placing MVP cutter plates at each extension to displace the soil. Extensions can be added on quickly to reach the necessary depth. The square upset socket connection provides direct transfer of installing torque through the solid shaft and not through the bolts. Once the pile is in place, the appropriate termination is used to transfer the load from the structure.

1.5", 1.75", and 2" Solid Square Shaft Helicals

Helical Anchor Lead Sections

Helical Anchor Lead Sections consist of a central solid square shaft with one or more helical-shaped steel plates welded to it. The RCS solid steel square shaft material conforms to ASTM A-576 special quality hot-wrought steel. Each lead section has an earth-penetrating pilot point at the bottom end of the shaft and a transverse through hole at the upper end of the square shaft to accommodate a bolted connection to a mating shaft extension section.

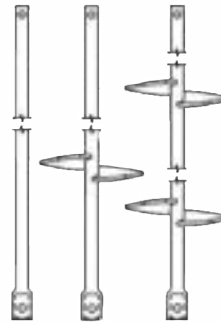

Extension Sections

Helical Anchor Extension Sections consist of a central solid square shaft and are offered with and without helical plates welded to the shaft. Each extension section includes a transverse hole on the upper end of the square shaft to accommodate a bolted connection to a mating extension section or adapter/bracket.

Each extension section also includes an integrally forged square socket at the lower end of the shaft. The forged square socket is designed to fit over the lead section or other extension. Installing torque is transmitted through the upset socket and not the bolt. A transverse hole permits connection to the lead or extension section with a bolt and nut.

Corrosion Protection

Foundation Anchor Lead Sections, Extension Sections, connection bolts and nuts are hot dip galvanized per ASTM A123/A153, as required.

Installation Torque Rating

The Ultimate Mechanical Strength Torque rating includes Lead Sections and Extensions

- 1-1/2" D6 RCS shaft Multi-Helix 5,500 [ft-lb.]
- 1-1/2" D7 RCS shaft Multi-Helix 7,000 [ft-lb.]
- 1-3/4" D10 RCS shaft Multi-Helix 10,000 [ft-lb.]

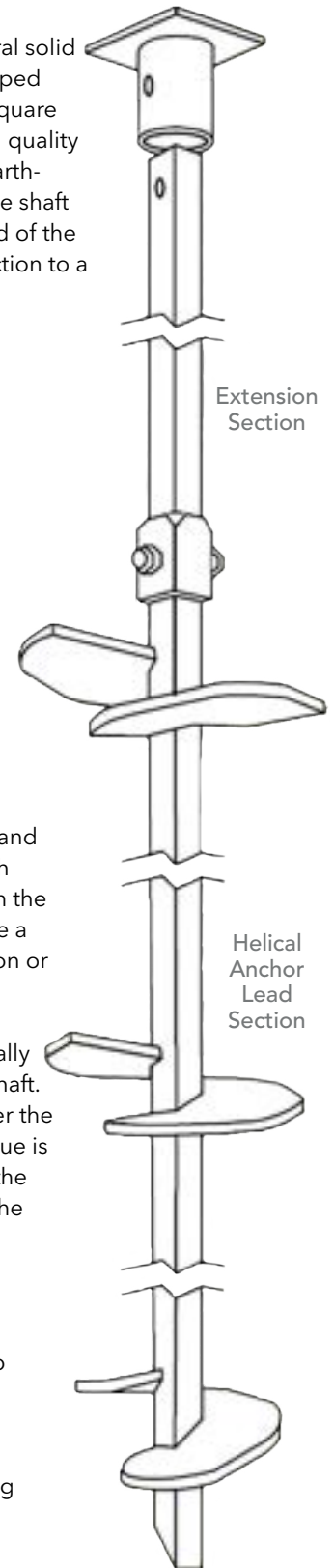

Restoration and repair of damaged foundations.

Custom designed pile system: Basin Head Fisheries Museum – Prince Edward Island, Canada

The historic 1941 Basin Head Cannery Building was floated off its original timber pilings and moved ashore during a severe storm event. Attempting to move the Cannery back to its original location was quickly ruled out due to the risk of further damaging the structure. Local engineers recommended a new foundation built on helical piles installed from within the building.

Due to the presence of unstable strata beneath the building, MPS designed a modified combo pile system consisting of 3-1/2" OD pipe pile extensions with a single 12" diameter helix and a 1-1/2" RCS lead section.

This pile was able to readily penetrate and embed into the dense glacial till and provided the required later resistance in the loose upper soil layers. The galvanized piles were encased in polyethylene sheathing for extra corrosion protection and to create a slip surface that would prevent ice accumulation. The piles were terminated with U-shaped saddle brackets, which supported the timber floor joists.

Temporary wall stabilization: Stone Ridge Public Library – Stone Ridge, NY

Temporary support was needed to stabilize two walls of this historic early-1900's library that had begun to bow outward. The original plan was to use deadman anchors to support the temporary bracing. After an initial review, these were shown to be a very costly anchoring measure as well as an eye sore.

The design was amended to a system using helical piles to resist the compression and tension loads exerted by the leaning wall. 6 1-1/2" RCS helical piles were installed on each wall to an average depth of 15ft below working grade. 4 piles on each wall were installed vertically to resist the 5 kip compression/tension loads. The remaining two were battered at 54 degrees for added stability. The shoring system and helicals were removed upon completion of the permanent walls.

Restoring sliding Tamura residence – Woodinville, WA

A soil-slip caused the foundation wall of this three-story residence to bow, break and separate. In total, the wall had moved 29" laterally and 12" vertically.

The repair project began with the installation of 24 1-1/2" RCS anchors with a single 12" helix to stop the lateral movement of the wall. Another 18 anchors were installed to stop the vertical movement of the wall. To pull the wall back to plumb and level the house, the basement slab was removed, and 150 cubic yards of fill was excavated. The wall was then slowly pulled back into place laterally and horizontally.

A new reinforced shotcrete wall further stabilized the damaged foundation. The excavated basement was backfilled with EPS Geofoam to reduce the load on the wall and slope. Another 24 tiebacks were installed on the front wall of the residence and 60 underpinning piles were added to support the new basement slab.



Warning signs of foundation failure.

Visible structural damage to the inside and/or outside of an existing building is an early sign of foundation failure. You may notice cracks in brick siding, above door and window frames, and floor slabs. Walls may be bowing in or leaning out. Windows and doors may stick. Trim and molding may be misaligned. MacLean Civil's Foundation Repair Systems can instantly restore your structure's stability and stop future settlement so that these aesthetic repairs can be completed.

What causes damage?

Hot, dry conditions and decomposing organic material can cause soil to settle, leading to cracks and differential settling of the foundation. Tree roots can outgrow their spaces and creep under foundations, causing them to buckle. Leaking water lines or poor drainage can soften soil, caving it in below foundations. And sites that were improperly prepared initially can also have inherent stability problems. No matter what the cause of foundation failure, MacLean Civil Products has the solution.

Simple repairs, inside or out

There's no need to dig out or remove entire old, damaged foundations. When you use MacLean Civil's Foundation Repair Systems, all that's required is excavation of a small work area, whether the repair is inside or out. There's no heavy equipment needed, no vibration and no hassles.

Our helical piles can be used to stabilize walls that have moved and restore foundations to stable positions, permanently securing them in place again. How do they work? Helical piles are installed through loose upper soil layers and embedded into deeper and more dense (load bearing) soil. Proprietary brackets are attached to the concrete foundation at intervals in the damaged area. A jack lifts the foundation to the required position. It's then firmly bolted to the bracket, which permanently transfers the structure's load to stable strata.

Straighten and stabilize bowed walls.

MacLean Civil's tieback anchors can be used to straighten bowed foundation and retaining walls. For a single helix installation, first excavate to the base of the foundation to a width sufficient to fit the single helix lead. A 3-inch diameter hole is cored through the foundation wall. The top of the lead section is placed through the hole from outside the foundation wall and connected on the inside with an extension. The tieback is then installed to the required distance.

For multiple helix leads, a hole is cored through the foundation wall to permit the largest diameter helix to pass through. Installation of the lead and extensions takes place from the inside. A threaded adapter with the upset socket is connected to the extension and a bearing plate on the inside wall. The nut is turned to apply load to the tieback anchor and stabilize or straighten the bowed wall.

MacLean Civil foundation and underpinning bracket

MacLean Civil Products offers several styles of foundation repair brackets to meet each project's requirements. Typical brackets are engineered for load capacities to 120 kips and for the range of square shaft piles to 2" RCS solid steel square shaft and round pipe piles to 4.5" diameter.

Brackets for new construction are typically placed on top of the extension. Brackets are available for placing onto either RCS solid steel square shaft or round pipe piles for new construction.

Brackets for foundation repair applications are available for placing onto either RCS solid steel square shaft or round pipe piles. The helical foundation pile is installed to the required depth. The bracket for outside wall repair is installed at the base of the foundation wall of the excavated hole. The bracket is bolted to the foundation wall. A hydraulic jack is used to lift the wall to the required level using the installed pile as a reaction force. A threaded assembly locks the bracket to the pile.

The bracket for floor repair is installed by coring a hole on the floor sufficient to permit the largest helix diameter to pass. A bracket is mounted to the helical pile to support the flooring from below.

The brackets are manufactured from ASTM A-36 steel and either hot dip galvanized to ASTM A-153 or not galvanized as required.

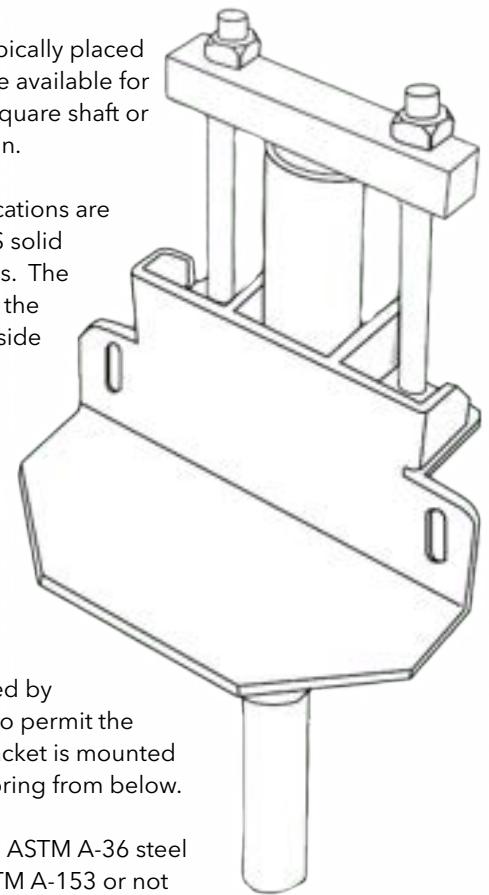

Limited access? No problem.

If you have a challenging site with limited access like low overhead or restricted width, MacLean Civil's helical foundation piles are the right products for the job. They can be installed using lightweight hydraulic equipment that fits into even the tightest work spaces. There's no soil spoils to remove and they install in any weather with just a small crew needed.

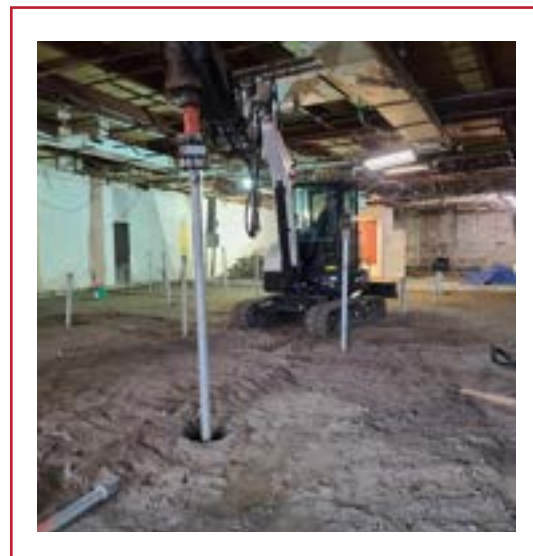

Solid reason to choose MacLean Civil Products.

Sewage replacement job: Hi Tech Copy Center and Williams Pharmacy – Saint Louis, Missouri

A box culvert and storm sewer system needed to be relocated from underneath the Hi Tech Copy Center and Williams Pharmacy. To do this, both structures needed to be stabilized. Helical piles were selected as the best method to stabilize both structures due to their ability to resist tension and compression loads.

After excavating and exposing the footing, 15 total 3.5" piles with 8/10/12" triple helix configuration were installed to a depth of 25 feet to resist a 75 kip load.

Suspension bridge – Colchester, New York

Temporary supports were needed to support the weight of a bridge to allow maintenance crews to replace the bearings and U-bolts. Four 1-3/4" RCS anchors were installed and pre-tensioned to 30 kips. Suspension cables were ran from the bridge and to guy adapter terminations bolted to each anchor.

Upscale residential home: retaining wall – Holmdel, New Jersey

A homeowner was interested in building on a lot that had been deemed practically unusable because it was primarily occupied by a large hill that extended beyond the lot. Engineers agreed that a large permanent retaining wall was needed to arrest potential foundation creep and anchor the building.

The retaining wall features two levels of helical tiebacks installed an average of 50ft to resist tension loads of 50 to 100 kips. 40 total helical anchors, a mix of 1-3/4" and 2" RCS, were installed with 8"-10"-12" triple helix configurations.

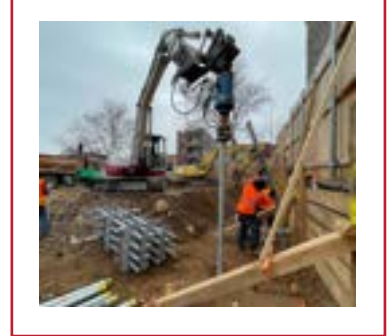

The advantages of tieback anchors.

Helical piles can be installed at any angle and are often used in tension applications such as guy wires, retaining walls, tent supports, buried pipelines and moorings. The helical anchors are installed through looser soils and embedded into denser, load bearing soil. They can be used to stabilize and restore bowed basement walls that have been damaged by poor drainage or expansive soils.

The best way to nail down stability.

MacLean Civil's soil nails are a solid choice for vibration free installations such as construction next to existing structures and reinforcement of embankments. In areas where rain could create a slide of slip plane soil, metal mesh is applied and sprayed with shotcrete or gunite to hold the outside surface in place. Using top-down excavation, the nails are quickly screwed into the soil using standard installation equipment and immediately ready for loading. There's no waiting or cure time compared to traditional grouted soil nails. Bearing plates and threaded bolts attach easily for quick stabilization of soil.

Tieback Anchors

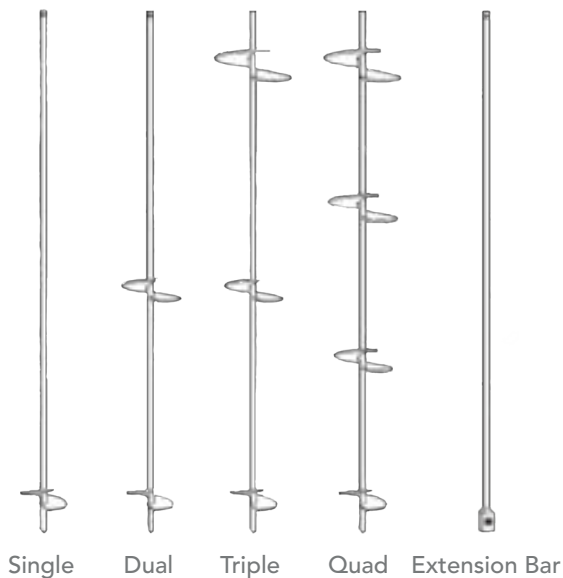

Tieback soil nails and terminations

Providing the termination to fit your application and stabilize your load.

Extension sections, adapters and connection bolts and nuts are hot dip galvanized per ASTM A-153.

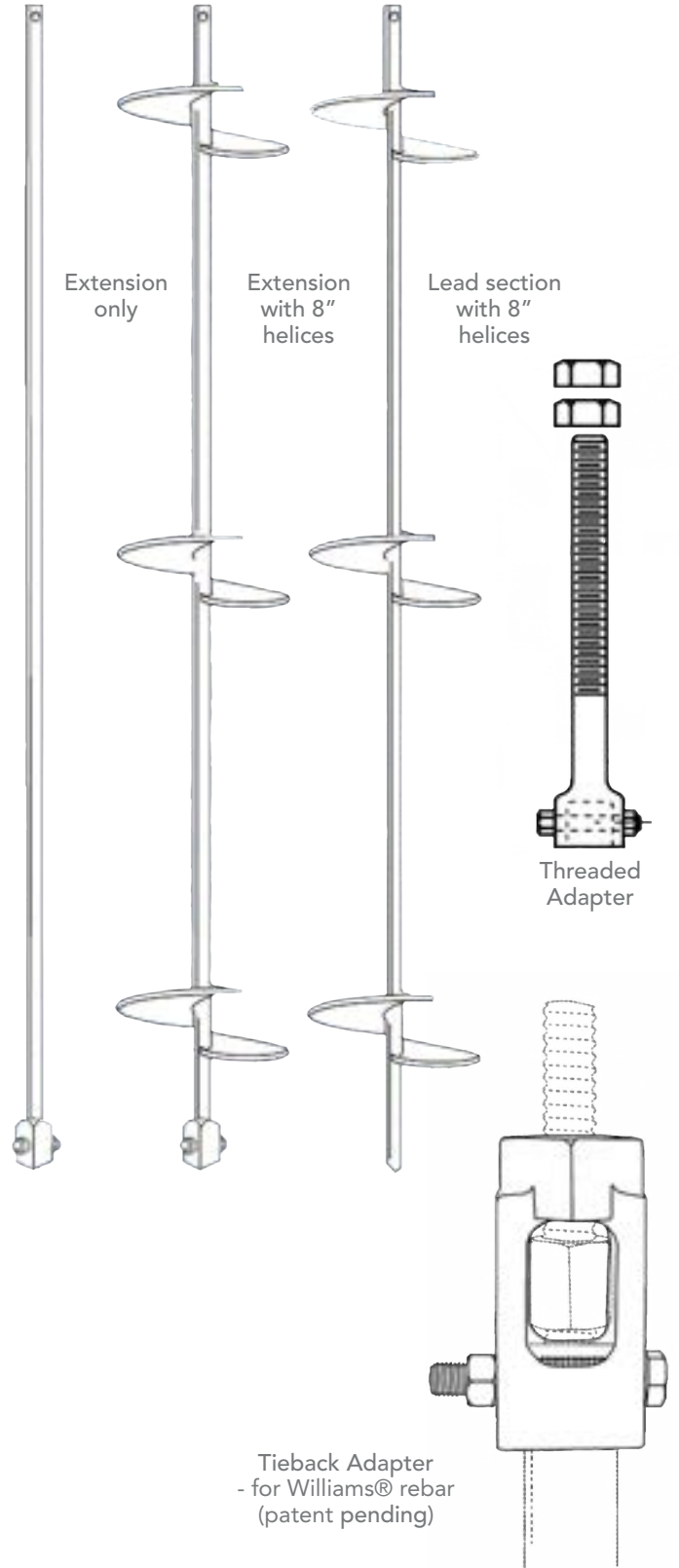

REACH OUT TO US
FOR MORE INFORMATION ON
HELICALS, GROUTED PILES OR
OTHER MPS CIVIL PRODUCTS



Find our Distributor
Locations near you



More Information on
Helical Anchors and Piles

