

JSS	REVISED BY:	REVISION DATE	ECO #

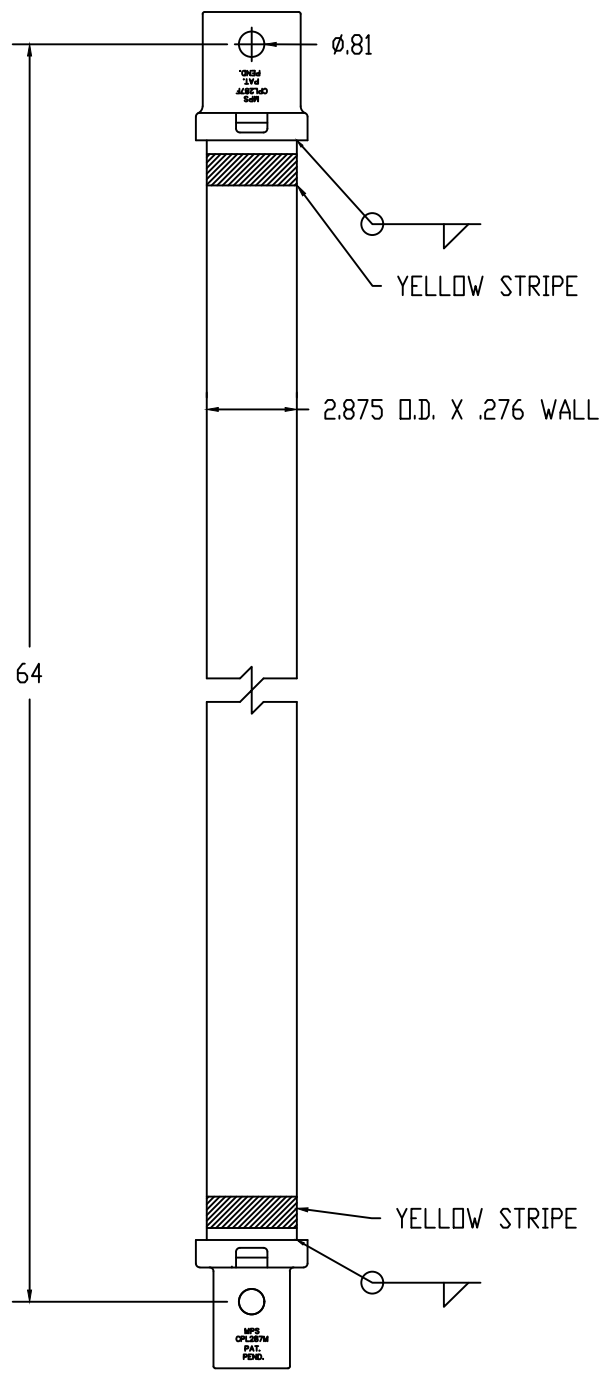

NOTES:

MATERIAL:
 COUPLER - STEEL, 40 KSI YIELD
 PIPE - SHAFT STEEL, 50 KSI YIELD

WELDING REQUIREMENTS:
 ALL WELDING TO BE PERFORMED BY WELDERS CERTIFIED UNDER SECTION 5 OF AWS D1.1

FINISH:
 HOT DIP GALVANIZED PER ASTM A123
 HOT DIP GALVANIZED PER ASTM A153 (HDW)

DIMENSIONS: INCHES

HARDWARE:
 HEX HEAD BOLT, 3/4" PER ASTM A325 (2 EA)
 HEX JAM NUT, 3/4" PER ASTM A563 (2 EA)

MECHANICAL RATING:
 TORQUE - 8,000 FT-LBS
 Kt FACTOR - 9
 ULTIMATE AXIAL CAPACITY - 90 KIPS

This drawing contains confidential information that is the property of MacLean Power, L.L.C. ("MacLean"). Use of MacLean's confidential information without MacLean's express written consent is strictly prohibited and may expose you to legal liability. If you believe that you received this material in error, please destroy it or return it to MacLean Power, L.L.C., Kingsley Park Five, 481 Munn Rd. Suite 300, Fort Mill, SC 29715, USA.



WWW.MACLEANPOWER.COM

CATALOG NUMBER: P28HE64		
SHEET NAME: Sheet1	1 OF 1	
DRAWING DESCRIPTION: PIPE EXTENSION P28H 2-7/8" X 64"		
DRAWN BY: DH	DATE: 03/09/20	APPROVED: DR